

J41H(2.5MPa)

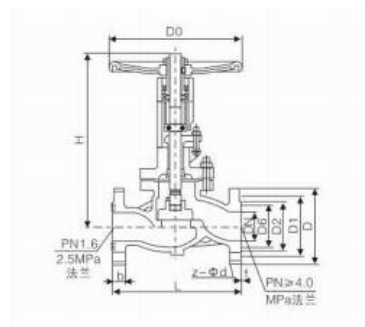

выбирать Расследование Ду(мм) л Д Д1 Д2 б ж Z- φd X手 X电 D0

10	130	90	60	40	16	2	4-14	198	-	120
15	130	95	65	45	16	2	4-14	218	-	120
20	150	105	75	55	16	2	4-14	258	-	140
25	160	115	85	65	16	2	4-14	275	-	140
32	180	135	100	78	18	2	4-18	280	-	160
40	200	145	110	85	18	3	4-18	330	-	180
50	230	160	125	100	20	3	4-18	350	645	200
65	290	180	145	120	20	3	8-18	400	690	280
80	310	195	160	135	22	3	8-18	355	715	280
100	350	230	190	160	24	3	8-23	415	770	320
125	400	270	220	188	28	3	8-25	460	780	360
150	480	300	250	218	30	3	8-25	510	875	450
200	600	360	310	278	34	3	12-25	710	967	500
250	650	425	370	332	36	3	12-30	786	-	550
300	750	485	430	390	40	4	16-30	925	-	600
350	850	550	490	448	44	-	16-34	1075	-	700
400	950	610	550	505	48	-	16-34	1235	-	800
450	1200	660	600	555	50	-	16-34	1235	-	1000
500	1250	730	660	610	50	-	16-41	1235	-	1350